

Intern Report 2013

Christian Carrico

Table of Contents

Chapter 1

- Section 1-1: Introduction
- Section 1-2: Shield Wall background
- Section 1-3: Side projects background.

Chapter 2

- Section 2-1: Shield Wall Introduction
- Section 2-2: Basic Design
- Section 2-3: Physical Model
- Section 2-4: Construction
- Section 2-5: CAD Models
- Section 2-6: Presentation

Chapter 3

- Section 3-1: Website

Conclusion

Chapter 1

Section 1-1

The purpose of this report is to outline the work I completed during my summer internship of 2013. I will describe my contribution to the shield vault, a structure that will be used in the Advance Beam Laboratory I will also go over smaller projects that were pursued this summer.

Section 1-2

The shield vault will be necessary to safely operate the six-MeV linear accelerator (LinAc) that will be used at the Advanced Beam Laboratory safely. The Advanced Beam Laboratory is a new addition to Colorado State University's Foothill campus. The main purpose of the vault will be to adequately block the radiation generated by the six-MeV (Mega-electron volt) L-Band electron LinAc, while still allowing safe access for personal and essential equipment.

Several side projects were also accomplished during this summer, including the construction of the CSU Accelerator Laboratory website. The website was completed during the beginning of the summer, and then vastly improved later on with the expertise of Nikhil Bhattasali.

Chapter 2

Section 2-1

The shield wall project began with a basic floor plan and several design constraints. The finished structure will be a non-permanent vault made with 4-foot thick walls and topped with a 3-foot thick ceiling. The vault would include a 'maze' styled entrance to allow access into the structure without compromising its ability to contain radiation. I was also instructed to consider practical options for safe access into the structure for

supporting apparatuses such as RF power and the laser transport system. (Figure 1)

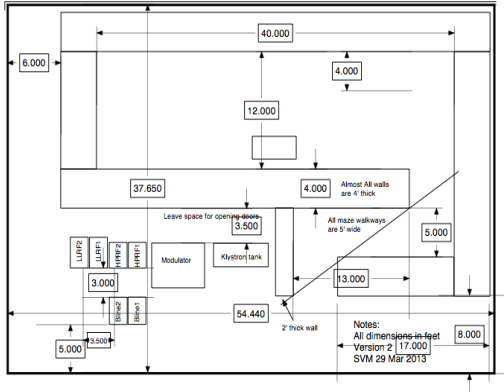

Figure 1

Conventional radiation safety standards demanded their own constraints. These included that the thickness of the walls and ceiling had a minimum value to be considered safe. Any junction between two blocks has is a potential radiation hazard and needs to be shielded so that there is no direct seam to the inside of the vault.

The facility that contains the shield wall structure also adds to the design constraints. These included the height of the heating and plumping

elements running along the length of the ceiling, and the size of the access door into the building.

Of course, cost, practicality, and ease of construction also had to be considered during this project.

Section 2-2

With these constraints in mind, it was derived that the components of the wall had to be as large as possible to reduce the number of junctions between blocks, but small enough to manipulate the weight easily with a reasonable forklift. The main component of the wall portion of the vault was decided to be 4-foot wide by 9-foot high by 2-foot deep. These components weigh approximately 10,800 lbs., $((V)(150 \text{ lbs./ft}^3))$. (Figure 2)

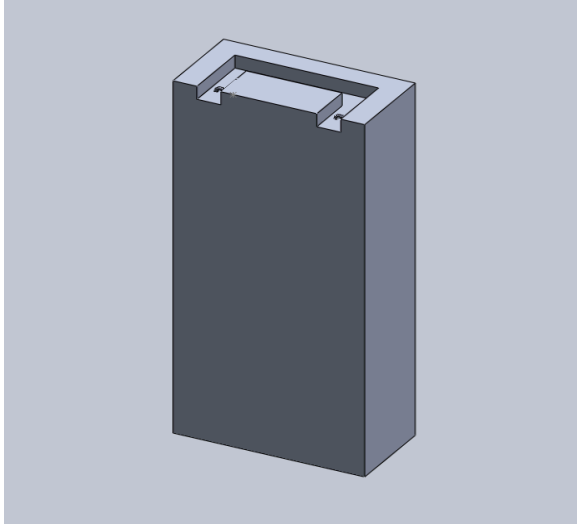

Figure 2 (Basic Block)

Two layers of these blocks will be used to create a combined thickness of 4-feet. The second layer of blocks will be placed centered on the seam of each of the previous layer's joints. By using this method, there is no danger of a radiation safety hazard. (Figure 3).



Figure 3 (Block Layering)

This basic block was used to make up as much of the design as possible, but there are some portions of the wall that need specific components in order to meet the floor plan's required dimensions. These blocks are dimensioned 5-feet wide by 9-feet high by 2-feet deep at 13,500 lbs. and 2-feet wide by 9-feet high by 2-feet deep at 5,400 lbs. The other block designs are just variations of the Basic Block, with either extended or shortened dimensions.

The ceiling was devised similarly. The shield wall structure was divided into two sections: the maze and the main vault. Each section needs a differently dimensioned ceiling to span the area required. The ceiling blocks designed for the maze are dimensioned 3-feet wide by 1.5-feet tall by 9-feet long at 6075 lbs. The blocks designed for the vault are dimensioned 4-feet by 1.5-feet by 14-feet and weigh 14,400 lbs.

The ceiling will be constructed in two layers to prevent any radiation safety hazards for the same reason as the wall.

Several features were built into the shield wall design to ease the construction process and add additional functionality to the structure.

These features include a “u-channel” which is a u-shaped recess that is built into the block. The base of the “U” runs the length of the entire block. Inside these channels are two rebar hard points. (Figure 4)

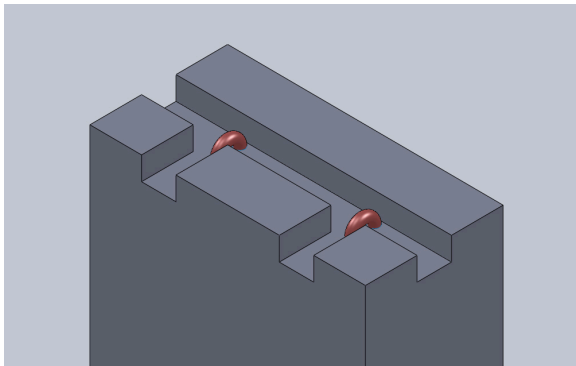

Figure 4 (U-Shaped Channels)

These channels serve multiple purposes for construction and for structural integrity. The rebar hard points (also seen in figure 3) are needed to lift

the blocks and set them into place needed to be countersunk from the top surface of the block to allow the ceiling to lay flush with the wall.

The channels will allow the shield wall to be chained together block to block, adding to the structural stability of the standing blocks. The dimensions of the channel were also chosen to accommodate a 6-inch tall by 4-inch wide beam to support the ceiling in necessary places throughout the vault to provide addition support for the weight of the ceiling.

The ceiling blocks also have hard points that are countersunk into concrete. This allows the ceiling blocks to lay flush with each other, while allowing them to be maneuvered onto the rest of the structure. (Figure 5)

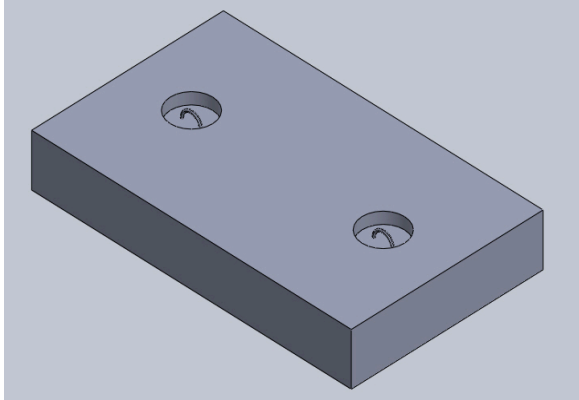

Figure 5 (Example of ceiling hard points)

In order to keep the thickness of the walls constant for radiation safety purposes, the recessed channels will be filled with lead shot after the block is maneuvered into place, and chained into the rest of the structure.

The vault ceiling will be modified during either fabrication or after it is placed to include several 10-inch holes that will serve as access points for the laser transport system and other equipment used to support the accelerator. To keep with radiation safety standards, the access points have to be shielded using several smaller blocks and a second ceiling. This second structure

will block any direct line of sight into the structure, which prevents radiation from leaving the structure.

Section 2-3

After the individual blocks in the project were defined, it was suggested that a physical model would reveal much about how practical the proposed design is. So using the wood shop located in F-Wing of the Engineering Research Center (ERC) in the Foothills campus, we were able to produce the blocks for the wall and ceiling to create a scaled replica of the shield vault.

This replica made visually identifying possible radiation safety hazards and weight concerns possible. Based on these observations, we made a few changes to the dimensions of our original blocks. The replica also gave shed some light on the fact that the dimensional tolerance on the blocks have

to be pretty low, because the limited space inside the Advance Beam Laboratory leaves little room for error.

During the creation of the model, several concerns about the Advance Beam Laboratory were brought to attention. These included several severe height limitations that had not yet been considered. In order to account for these new constraints we built them into our physical model, using plexi-glass and cardboard to represent the buildings walls, duct work, and piping. These additions helped solidify not just the plans for the shield wall, but for the construction process as well.

Section 2-4

By using these new additions to the model we were able to confirm that our wall design was still feasible, and we proceeded to define a plan for construction.

Due to the large size of the blocks and the limited space inside the Advanced Beam Laboratory, the forklift required to lift the blocks had to be small enough to work inside the building, while able to lift the weight required by the wall's design. We searched for local lenders willing to rent a forklift with a lift capacity capable enough to manipulate the purposed pieces of the shield wall, and researched lift straps and strategies needed to lift the weights required.

A numbering system was introduced into the model to define the order in which the individual pieces of the shield vault would be placed. This is necessary to ease construction and to avoid the risk of redoing sections of the wall because of misplaced blocks. The numbering system also applies to the accelerator and its supporting equipment. Once the vault is in place, it becomes impossible to move the accelerator and

supporting equipment around the laboratory. So the accelerator is number with the rest of the blocks to ensure that they get to their needed locations.

In the future, it is possible that a crane-type of device will be constructed to ease the maneuvering of the equipment outside of the vault.

Section 2-5

To prepare for fabrication, we produced a CAD model of the entire design. This model incorporates several elements outside of just the shield wall model. There is a basic CAD model of the room where the vault will be placed, the laser transport system, and the RF waveguides. These files are ready to be sent to concrete vendors for price estimations and other inquiries. In the future, Solidworks , the CAD program used to design the digital version of the blocks, might be used to conduct stress

tests and other structural integrity verifications. (Figure 6)

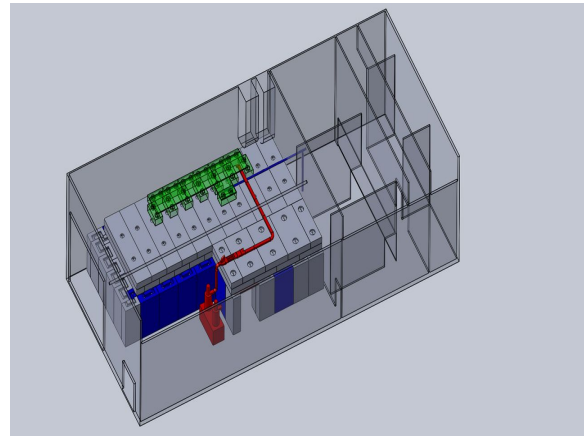

Figure 6 (Finished Product)

Section 2-6

To finish the work on the shield vault, a presentation was put together showcasing the work and detail that went into the project. This slideshow is being put together for several audiences to gain approval for the current vault design. This slide show incorporates the work from everyone who contributed to the wall, including calculations for the walls thickness, the different shield wall components, components for the laser transport system, and even details concerning construction.

Chapter 3

Section 3-1

During the summer, significant progress was also made to the accelerator team's website. The website was started late in the 2013 Spring Semester, and by the beginning of summer there was a very basic website live and linked the Colorado State University's Engineering website.

This site was very basic and included just basic HTML, but late into the summer another intern, Nikhil Bhattasali, began redesigning the website for better functionality, appearance, and overall quality. (Figure 7)

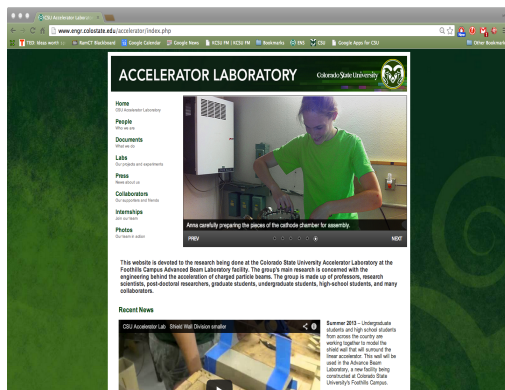
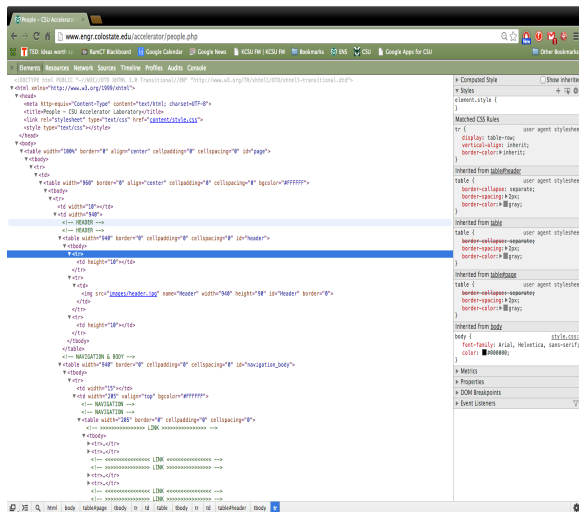

Figure 7 (Home page)

The final product is completely different from the original website. Several improvements were made, including better use of CSS style sheets and a universal inclusion of PHP. The CSS style sheets made the entire website much more uniform. The PHP vastly improved on the organization of the code and functionality of the website.

In addition to the visual improvements done to the website, the project's main success is the compartmentalization and organization of the HTML and PHP code. Great care went into using comment sections to explaining how certain parts of the code work. By doing this, it was our hope that anyone with a basic knowledge of HTML would be able to alter and even continue to improve the website. (Figure 8)



thank you John Harris and Jorge Martinez
for your patience and guidance.

–“Stay Strong, Jorge.”

Figure 8 (Example of code organization)

Conclusion

Dr. Sandra Biedron and Dr. Stephen Milton assigned me the shield wall project during the 2013 Spring Semester, but the resulting product is the collaboration of many different students and researchers. All of whom are equally responsible for the shield wall. Without their contributions to the final product, the shield wall design would not be near the quality it is now. So thank you Alysia Dong, Lucas Kang, Kevin Kenny, Nabeel Moin, Joshua Smith, and John “Max” VanKeuren, for your talent and effort. And